

Halogen lamps

Low-voltage dichroic reflector Diamondline Pro



Diamondline Pro (50 mm) 24°



Diamondline Pro (50 mm) 10°

Diamondline Pro (50 mm) 36°

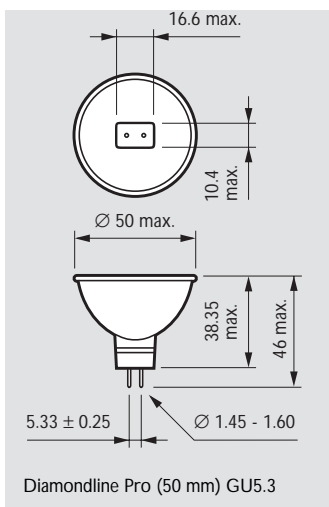

Dimensions in mm

Halogen reflector lamps with a special "cool daylight" colour impression. This lamp further consists of an extra-low-voltage halogen burner optically positioned in a glass reflector which has a special heat-transmitting and light-reflecting dichroic coating. This combination of the burner and the reflector results in a high-intensity beam with a clearly defined beam spread. The dichroic cool beam reflector coating transmits the infrared radiation (heat) backwards through the glass and reflects the visible radiation (light) forward, thus resulting in a cool daylight beam impression.

Features

The most important features of the Diamondline Pro lamp range are:

- a high-pressure Xenon gas filled burner
- axial filament optimally aligned in a reflector with hard dichroic coating providing constant high quality, durability, maintenance over lifetime and aesthetics.
- with front glass
- average lifetime of 4000 hrs.
- range of 35 W and 50 W 50 mm types.
- colour temperature of 4100 K
- excellent colour rendering (Ra = 100)
- GU5.3 base: extra retention in luminaire
- universal burning position
- dimmable

Applications

Diamondline Pro lamps are ideally suitable for accent, task and decorative lighting in jewelry shops (diamonds, silver, gold, cristal).

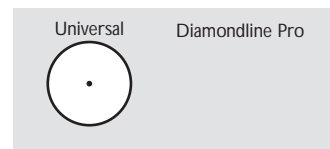

Burning position

Commercial name	Type	Voltage	Wattage	Beam angle	Cap/base	ANSI	Max. luminous intensity cd	Lamp life 50% h	EOC
		V	W						
Diamondline Pro	14656	12	35	10°	GU5.3	FRB	5400	4000	428813
DiamondlinePro	14658	12	35	24°	GU5.3	FRA	1700	4000	428844
Diamondline Pro	14659	12	35	36°	GU5.3	FMW	1000	4000	428875
Diamondline Pro	14668	12	50	10°	GU5.3	EXT	6400	4000	428905
Diamondline Pro	14670	12	50	24°	GU5.3	EXZ	2700	4000	428936
Diamondline Pro	14671	12	50	36°	GU5.3	EXN	1200	4000	428967

Halogen lamps

Low-voltage dichroic reflector Diamondline Pro

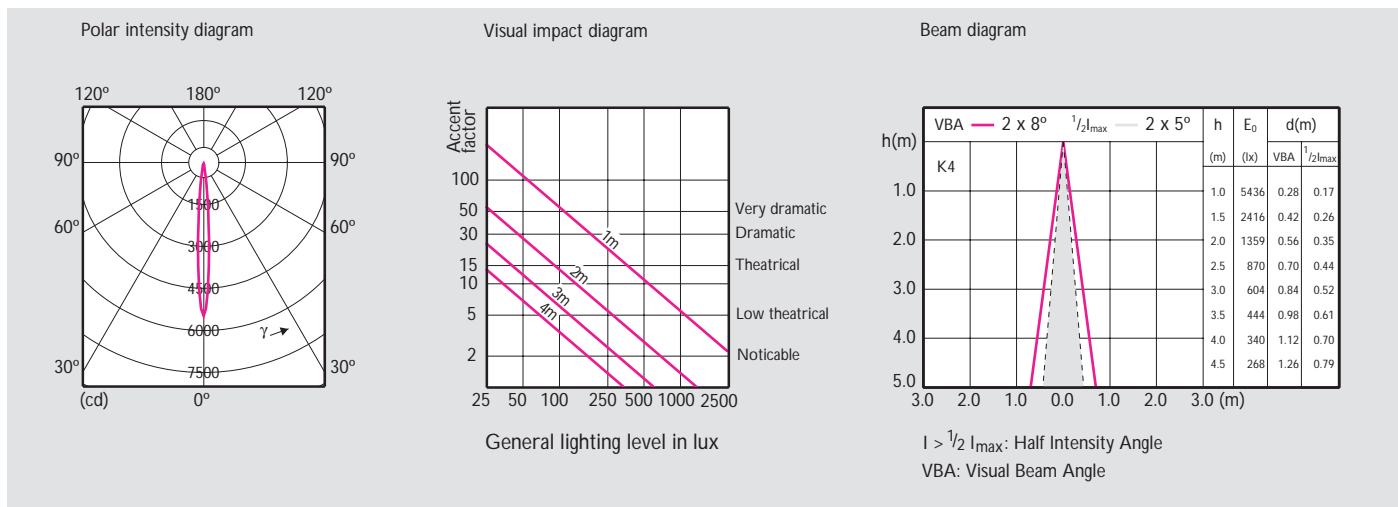

Diamondline Pro 12V 35W 10dgr

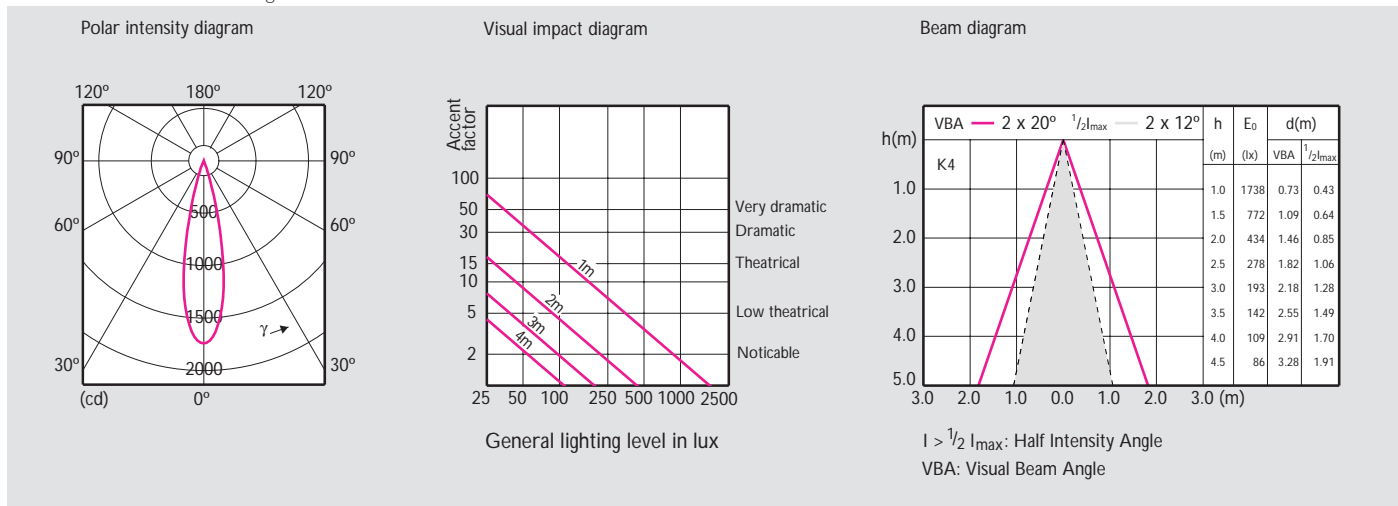

Diamondline Pro 12V 35W 24dgr

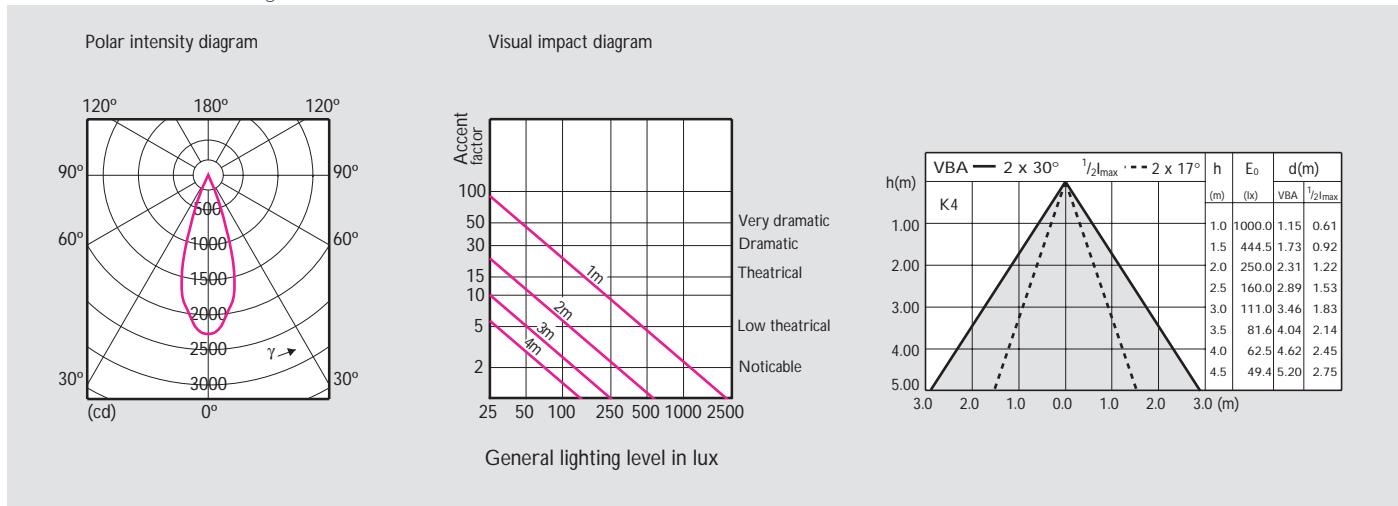

Diamondline Pro 12V 35W 36dgr

Halogen lamps

Low-voltage dichroic reflector Diamondline Pro

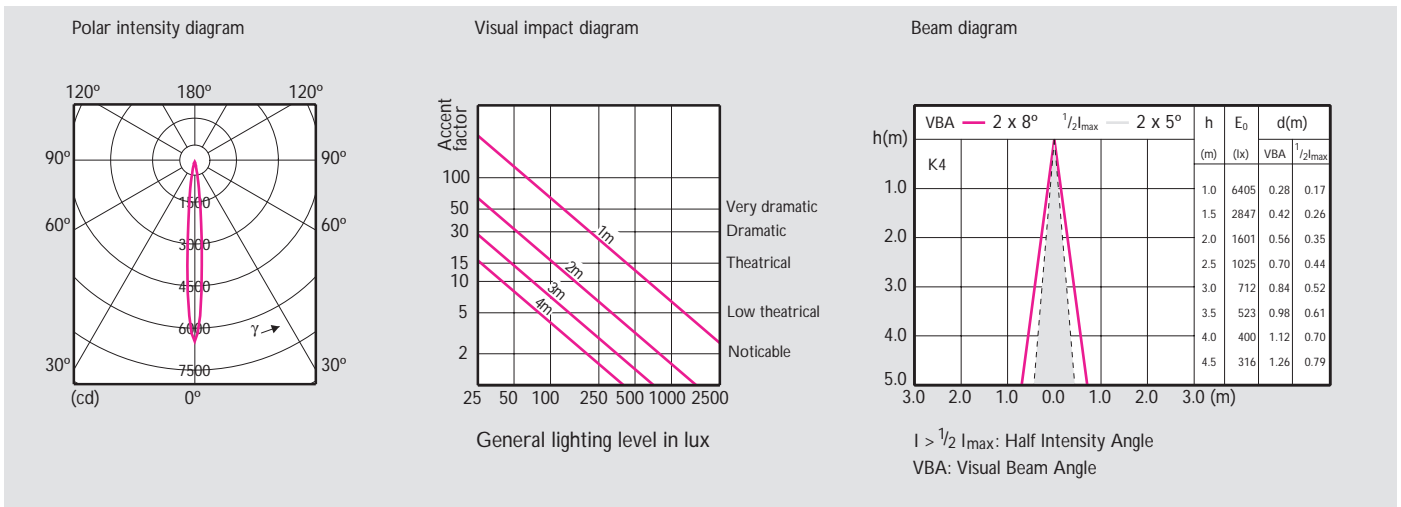

Diamondline Pro 12V 50W 10dgr

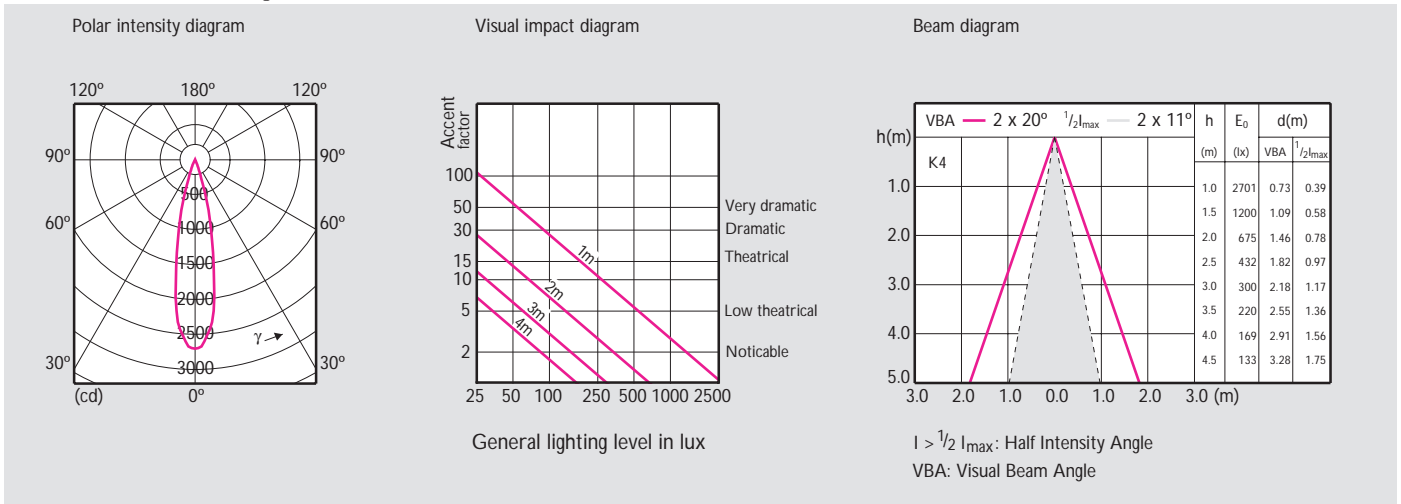

Diamondline Pro 12V 50W 24dgr

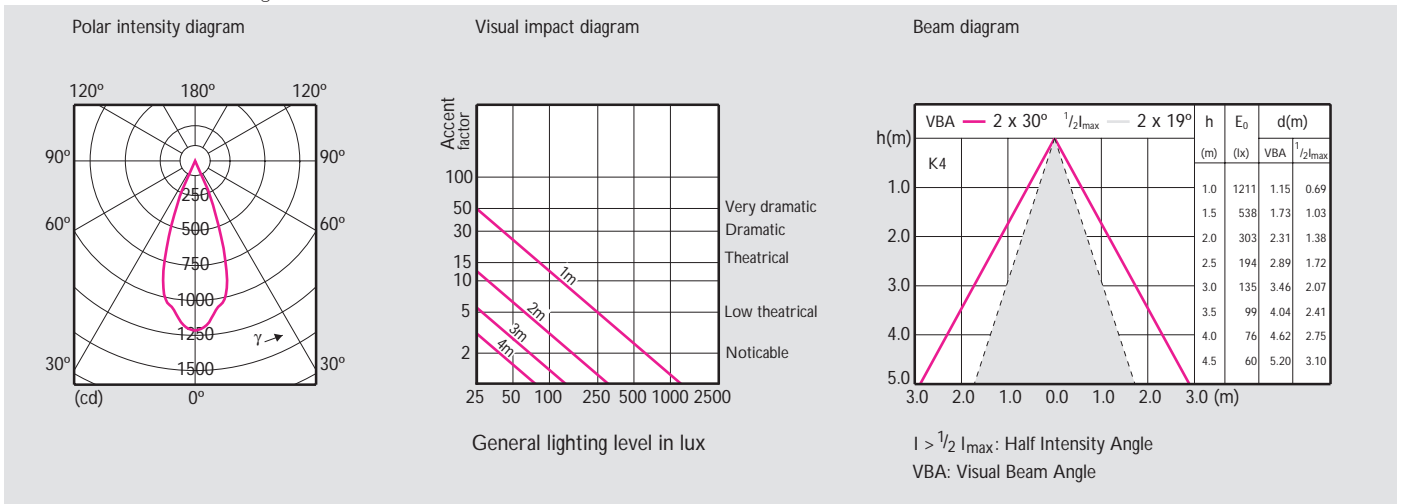

Diamondline Pro 12V 50W 36dgr